

PIN BRAZING CLAMPS

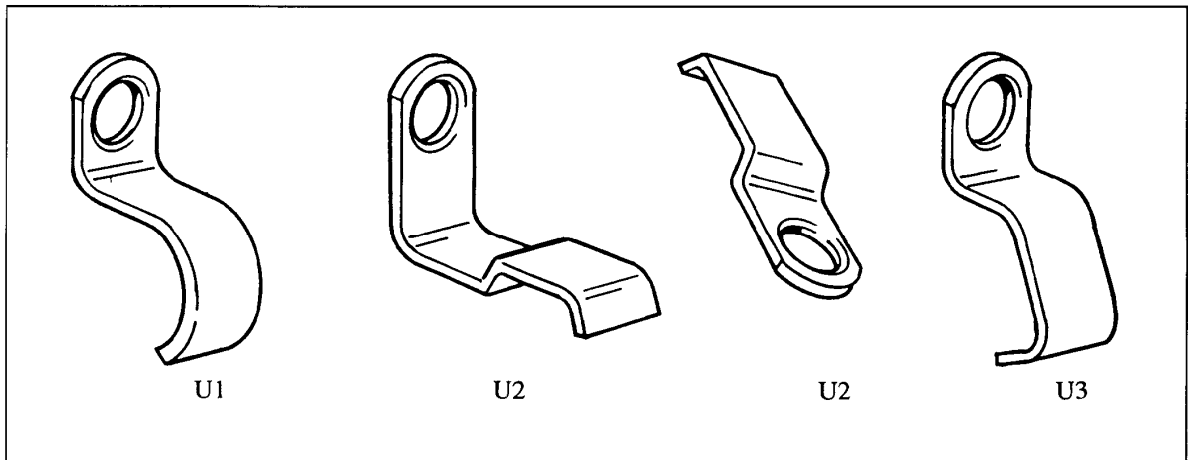

Pin brazing clamps

Pin brazing clamps are used for fixing cables or for mounting electric point heaters on the rail. Being made of annealed copper, the clamps can be bent during the fitting/removal of cables or electric heaters.

For clamping work on points where space is cramped and where the standard brazing gun will not reach, we recommend the use of an extended or angled brazing gun.

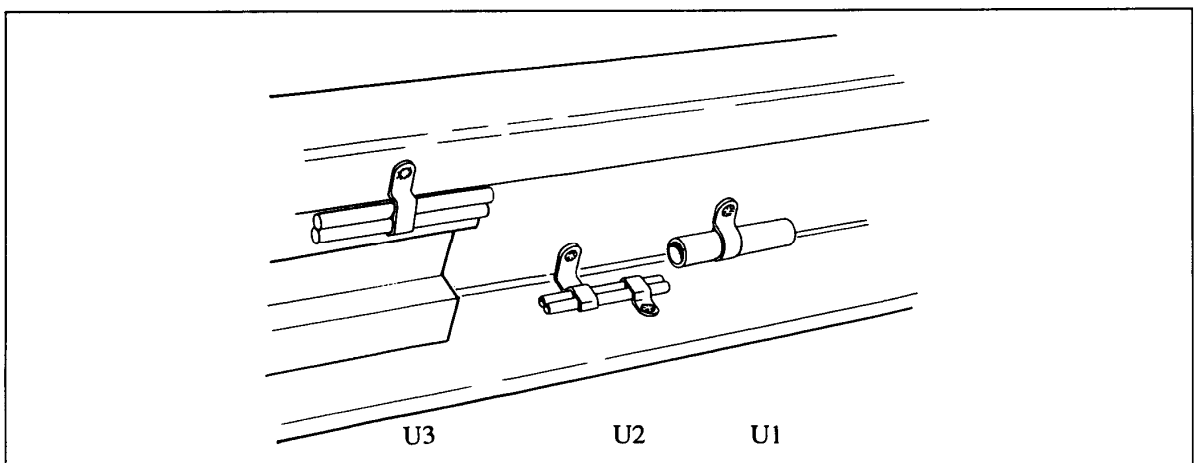

We reserve the right to make technical changes

Fig.	#	Designed for		Rec. Brazing pin	Remarks
U1	278 100 9030	Ø 6	100	F	
	270 082 8060	Ø 10	100	F	
	278 100 1830	Ø 14	100	F	
	278 100 4550	Ø 22	100	F	
	278 100 4530	Ø 25	100	F	
	278 100 5580	Ø 28	100	F	
	278 100 4110	Ø 32	50	F	
U2	278 100 1530	2 x Ø 6	100	F	
	278 100 6260	6 x 16	100	F	
	278 100 7820	2 x Ø 6	100	F	*
	278 100 4540	2 x Ø 6	100	F	* / **
U3	278 100 0260	2 x Ø 10	100	F	
	278 100 8600	3 x Ø 15	100	F	

* For installation on the rail foot or rail web.

** 20 mm from rail web

F= 270 075 1210 or 278 190 4320

We reserve the right to make technical changes